

ENDURO FI1217 TIPPER



Model code	FIV1PFX2RFBA (T)
Configuration	4x2 Tipper
GVM/ GCM	12,000kg / 13,500kg
Axles & GVM ratings	Front: Reverse Elliot (5,000kg) Rear: Full Floating (10,250kg) Ratio : 6.330:1
Kerb weight (10L fuel)	Front: 3,000kg Rear: 2,710kg Total: 5,710kg
Engine	FUSO 4D37, 3.9L, 4 Cylinder
Power / torque	170hp (125kW) @ 2500rpm / 520Nm @ 1500rpm
Transmission	FUSO G85 6spd Manual Syncromesh Ratios: 6.696 - 3.806 - 2.289 - 1.480 - 1.000 - 0.728 - Rev: 6.294

PTO (Std)	Ratio / max output speed: 1.607 / 2300rpm Max Output Torque Nm: 600 Max power Output @ 1000rpm (kw): 120
Suspension	Multi Leaf front and rear with Anti Roll Bars
Brakes	Full Air S cam with Auto Brake Adjustment & ABS
Wheels / Tyres	7.5 x 22.5 8 Stud ISO Tyres: 255/70R22.5
Fuel	200L + 27L Ad Blue
Electrical	24Volt / 80Amp Alt
Performance	14.7m Turning Circle; Max gradability = 36%* <i>*Theoretical performance only. Actual performance may vary under different conditions</i>
3 Seat Cab	All Steel Forward Control Tilting Cab with Door Side Intrusion Bars Arctic White (AW1) NEW Driver's Suspension Seat with Cloth Trim ELR 3-Point Seat Belts with Centre Lap Belt Air Conditioner / Heater / Demister 12V Accessory Power Outlet NEW Radio AM/FM + USB + Bluetooth Central Locking / Electric Windows Speedo, Tacho, Air Gauges Dual door mirrors + LH Front and Side Safety Mirrors Speedo, Tacho, Air Gauges Fuel level, Ad Blue Level, Engine Hours, Fuel Consumption Variable RPM Control Reverse Warning Buzzer
Tipper Body	6.5m ³ Internal dimensions (L x W x H): 3,744mm x 2,095mm x 836 mm
Material	ST 52.3 350 grade Floor - 4mm Side and headboard - 3mm

4D37

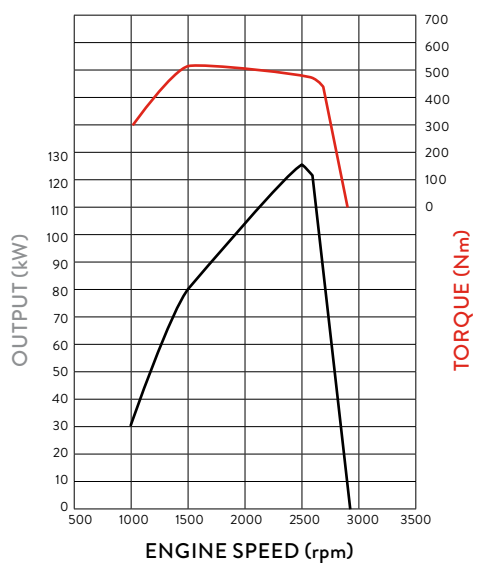

ENDURO FI1217 TIPPER

DIMENSIONS

Wheelbase	3,760
Overall Length	6,305
Overall Width	2,275
Overall Height	2,985
Frame Height At Rear Axle	970
Rear Over Hang (ROH)	1,270
Front Track	1,790
Rear Track	1,695

Note: All dimensions are in mm

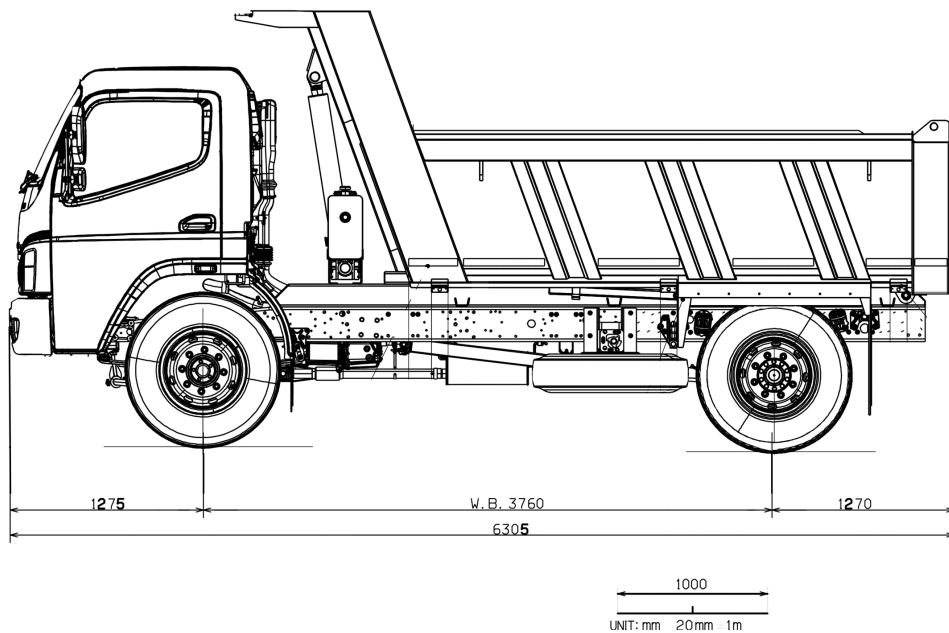

Scale = 1:50 (20mm = 1 metre). This scale is accurate when printed at full size (as available from your local FUSO dealer). If printing a downloaded pdf from the Fuso NZ website, please check your printer settings. Please be aware that printing these sheets at anything other than 100% size can alter the scale and cause incorrect measurements. Fuso NZ and its authorised dealers recommend customers seek professional advice from independent sources before commencing any engineering activities.

A policy of continual improvement means that specifications detailed on this sheet are subject to change without notice. Contact your authorised FUSO dealer to confirm current specifications. FUSO is a registered trademark of Mitsubishi Fuso Truck & Bus Corporation. Copyright © Fuso NZ Ltd (2020).