

SUPER LOW

FIGHTER FU1828

EURO 5 • 6x2 • **MANUAL**



GVM:
18,000kg



Power/Torque:
207kW/802Nm



Wheelbase:
5,870mm (L) / 6,200mm (M)

- 30,000km service intervals
- Isringhausen driver's seat
- 3yr / 200,000km Warranty (T&Cs inside)
- Low chassis height
- Rear air suspension

SPECIFICATIONS - FIGHTER FU1828

MODEL

6x2 FU1828	6 SP.	MAN	AIR SUSP.	FK65FLZ2RFAC (6X2)
6x2 FU1828	6 SP.	MAN	AIR SUSP.	FK65FMZ2RFAC (6X2)

WHEELBASE (mm)

5,870 (L)
6,200 (M)

GVM (kg)(optional)

18,000 (12,000)
18,000 (12,000)

GCM (kg)

20,000
20,000

ENGINE

Engine Version	FUSO 6M60-9AT2 Diesel
Configuration	6 Cyl. In-line OHC, 4-Valve
Type	Variable Geometry Turbo Charged Air to Air Intercooler
Displacement	7.5 litre (7545cc)
Power ECE Nett	199kW @ 2500rpm
Torque ECE Nett	785Nm @ 1100-2400rpm
Power (JIS Gross)*	207kW (281ps) @ 2500rpm
Torque (JIS Gross)*	802Nm (592lbft) @ 1100-2400rpm
Maximum Engine Speed (rpm)	2900
Compression Ratio	16.0:1
Cooling System / Oil Cooler	Water cooled with Viscous fan, 23.0L capacity. Engine oil cooler
Air Cleaner	Paper Element Type with Restrictor Indicator. Vertical Intake Mounted on Clean Air Side (RH)
Cold Start Preheat	Standard
Emission Control	Selective Catalytic Reduction (SCR) After-Treatment System (BlueTec), Positive Crankcase Ventilation (PCV)
Emission Level	Euro 5 (ADR 80/03)

*Calculated

6M60-9AT2

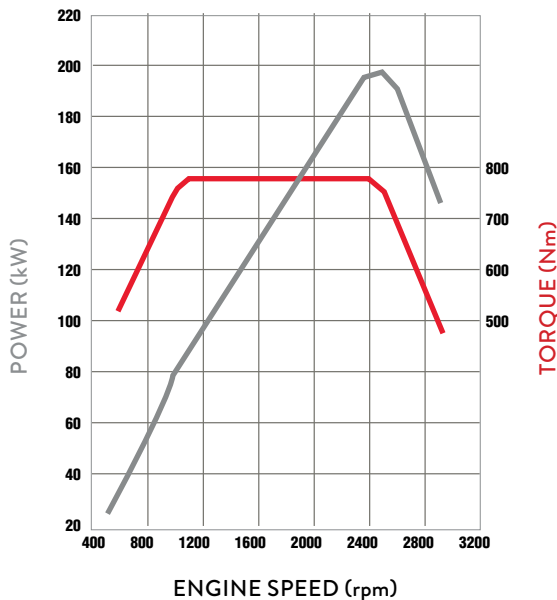

FUEL

Injection System	DENSO Common Rail System Electronically Controlled Direct Injection
Tank Type	Rectangular Steel Tank with Locking Cap
Fuel Capacity (L)	200
AdBlue Exhaust Fluid Capacity (L)	40

ELECTRICAL

Voltage	24V Negative Earth
Alternator Capacity	24V-80 amp
Battery Specification	Heavy Duty 2 x 12V, 100Ah/20hr
Headlamp Type	Halogen 2 x 70W/75W

CLUTCH

Clutch Model	FUSO C7M38
Type	Single Plate Cerametallic 380mm
Operation / Specification	Air Assisted Hydraulic

TRANSMISSION

Version	FUSO Manual M070S6-OD	
Type / Speeds	6 with Air Assisted Gearshift	
Features	Synchromesh 2nd-6th	
Ratios	1st: 6.807	5th: 1.000
	2nd: 4.172	6th: 0.774
	3rd: 2.396	Rev. 6.807
	4th: 1.504	
PTO Opening	LH Side	

PROPELLER SHAFT

Type	P10
Universal Joint	Needle Roller

FRONT AXLE

Axle	FUSO F500T "I" Beam
Design Capacity (kg)	5,000
Max Operating Capacity (kg)	5,000

FRONT SUSPENSION

Type	Taper Leaf spring and Double Acting Shock Absorbers
Size (mm)	1,300 x 70

REAR AXLE

Drive Axle / Tag Axle	FUSO D052 Full Floating Hypoid / TMCAUS PFRD 225
Design Capacity (kg)	9,500 / 9,500
Max Combined Operating Capacity (kg)	14,000
Ratio	4.875:1 (L) / 4.625:1 (M)

REAR SUSPENSION

Type	Air Suspension with Air Dump Control and Double Acting Shock Absorbers	
	Drive Axle	Tag Axle
Details	Fuso Trailing Arm with 2 air bags	Hendrickson HAS230 with 2 air bags
Trailing Arm	2 leaf	1 x Z beam

SPECIFICATIONS - FIGHTER FU1828

STEERING

Power Assisted	Tilt/Telescopic Adjustable Steering Wheel
----------------	---

BRAKES

Type	Full Air, Dual Circuit, FUSO Taper Roller, Automatic Brake adjustment, ABS
ASR (Traction Control)	Yes
Size Front / Rear (mm)	370 x 150
Park Brake	Rear Wheel Spring Actuated
Auxiliary	Exhaust Brake
Compressor	Water Cooled, 340cc Single Cylinder with Air Dryer

WHEELS AND TYRES

Wheel Type	11 x Single Piece Disc
Wheel Size	19.5 x 6.75DC-147-13t
Wheel Stud Pattern	8 stud 275mm PCD ISO
Tyre Size All	265/70R19.5
Spare Tyre Carrier	Provided

CHASSIS

Type	Parallel Channel
Size (mm)	230 x 80 x 8.0
Width (mm)	844

Refer to the bodybuilders guidelines on the Fuso website (www.fuso.co.nz) before mounting a body or modifying the chassis

INSTRUMENTS

Gauges	Speedometer with Odometer, Tachometer; Air Pressure (2); Fuel Level; Water Temperature
Colour Information Display	Fuel Consumption; Service Indicators Hour Meter and Tripmeter

STANDARD FEATURES

Airbag	Driver's Air Bag and Seat Belt Pre-tensioner
Hill Start System	Yes
Cab Cooling and Heating	Air Conditioner / Heater / Demister
Accessory Power	24V Accessory Power Outlet / Cigar Lighter
Audio	AM/FM + USB + Bluetooth Hands Free
Driving	Central Locking Electric Windows Cruise Control LH Transom Window Cup Holders (4) Rear Quarter Glass Fluorescent Cabin Lamp and Interior Reading Lamps Engine Idle Speed Control
Cab: External	Roof Mounting Points (max. static load 70kg) Front End-Outline Marker Lamps
Chassis	Chassis Mounted Tool Box Reverse Warning Buzzer

KERB WEIGHTS AND MAX AXLE LOADS (kg)

Model		Vehicle Ratings**		Max Axle Loadings**		Kerb Weights*		
		GVM	GCM	Front	Rear	Front	Rear	Total
6x2 FU1828 6 Sp. Man Air Susp.	FK65FLZ2RFAC(6x2)	18,000	20,000	5,000	14,000	2,460	2,660	5,120
6x2 FU1828 6 Sp. Man Air Susp.	FK65FMZ2RFAC(6x2)	18,000	20,000	5,000	14,000	2,470	2,670	5,140
6x2 FU1228 6 Sp. Man Air Susp.	FK65FLZ2RFAC(6x2D)	12,000	20,000	5,000	14,000	2,460	2,660	5,120
6x2 FU1228 6 Sp. Man Air Susp.	FK65FMZ2RFAC(6x2D)	12,000	20,000	5,000	14,000	2,470	2,670	5,140

* Weights (est.) includes 10L fuel and spare wheel and are subject to 2.5% variation (+/-)

** Vehicle ratings and max axle loadings may be limited by local regulations.

STANDARD FEATURES

Storage	Centre Seat Storage Console Rear Bunk Storage Pocket Dash Storage Tray 2 DIN Glove Compartment 1 Single and 1 Double DIN Slot for Accessor Overhead Storage Pocket with Lid RH Door Storage Pocket
---------	---

CAB FEATURES

Type	All Steel Forward Control Manual Tilt 44 deg.
Mounting	Hydroelastic Susp. 4 Point
Colour	Natural White (W31)
Interior	Fully Trimmed
Windscreen	Laminated Tinted
Windscreen Wipers	2 Speed + Intermittent Cycle with Integrated Washer Nozzles
Door	90 degree Opening Angle
Rear Vision Mirrors	Remote/Heated with Convex Spotter (Both Sides)
Seating Capacity	3
Seat Belts	2 ELR Lap Sash, 1 Lap
Seat (driver)	ISRI Air Susp. + Auto Levelling, Height, Tilt, Lumbar, Bolster and Dampening Adjust, Integral Headrest, Fabric Trim
Seats (passenger)	Centre: Low Back with Fabric Trim and forward folding LH Passenger: Fixed Base with Reclining Seat Back, Integral Headrest and Fabric Trim

OPTIONS

6.2" Touchscreen Media Unit AM/FM/DAB + USB + AUX, Apple CarPlay and Android Auto, Wi-Fi enabled for internet radio, Bluetooth, 32GB storage capacity, HD Reverse Camera included
Additional cameras for Media Unit (up to 4)
Truck Specific GPS Navigation
Reverse Sensors
Tyre Pressure Monitoring System (up to 36 tyres)
Wireless Phone Charging Pocket
Extended Warranty: Additional 2yrs / 100,000km

SERVICE INTERVALS

30,000km full service / 15,000km safety inspection
30,000km full service intervals, depending on application/use.
15,000km safety inspection, with greasing, required for reliability and to maintain warranty cover.

WARRANTY

3 years / 200,000km
Tipper body covered by 12mth / unlimited km warranty.
Refer to terms and conditions in the FUSO warranty booklet for full details.

SPECIFICATIONS - FIGHTER FU1828

PERFORMANCE

	L Wheelbase	M Wheelbase
Turning Circle (kerb to kerb - metres)	20.0	21.0
Electronically Speed Limited to (km/hr):	100	100
Engine Speed (rpm) at 90km/hr (top gear)	2130	2030
Gradeability at Rated GVM (theoretical)*	32%	30%
Gradeability at Rated GCM (theoretical)*	27%	25%

*Theoretical performance only. Actual performance may vary under different conditions

DIMENSIONS (MM)

	L Wheelbase	M Wheelbase
Wheelbase	5,870	6,200
Length Overall	9,905	10,235
Height Overall	2,530	2,530
Width Overall	2,270	2,270
Width Rear Axle	1,710	1,710
Width Front track	1,780	1,780
Width Rear Track	1,710	1,710
Width Frame	844	844
Height Frame at Rear Axle	858	858

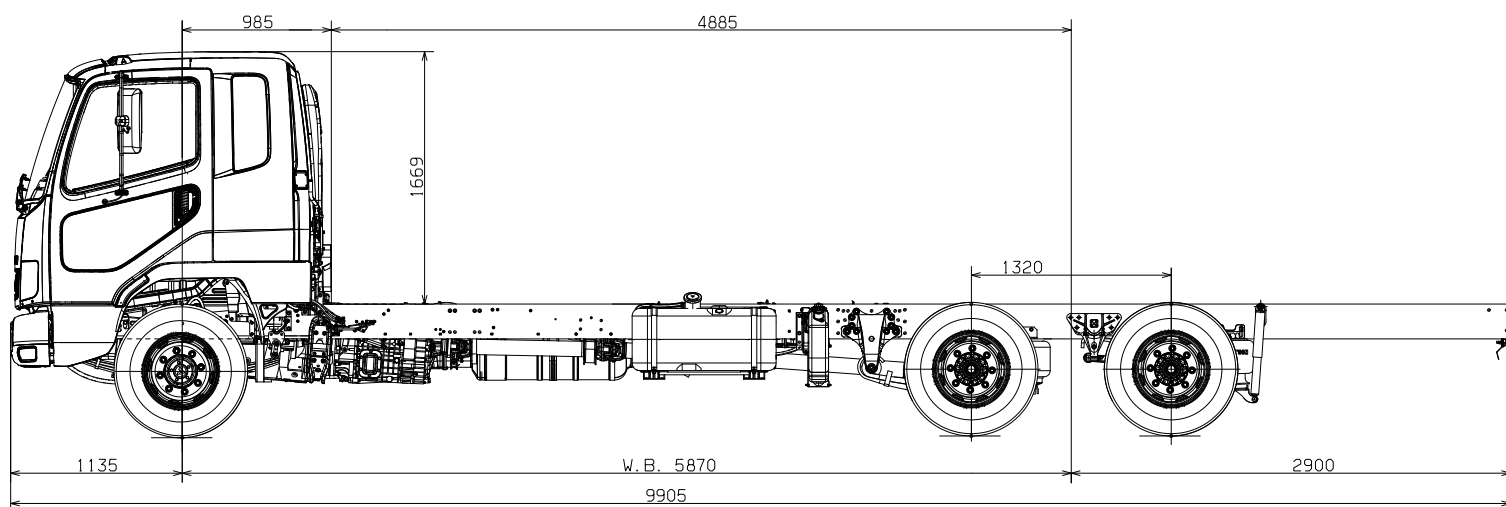

FIGHTER FU1828 – ‘L’ WHEELBASE

1000
UNIT: mm 20mm = 1m

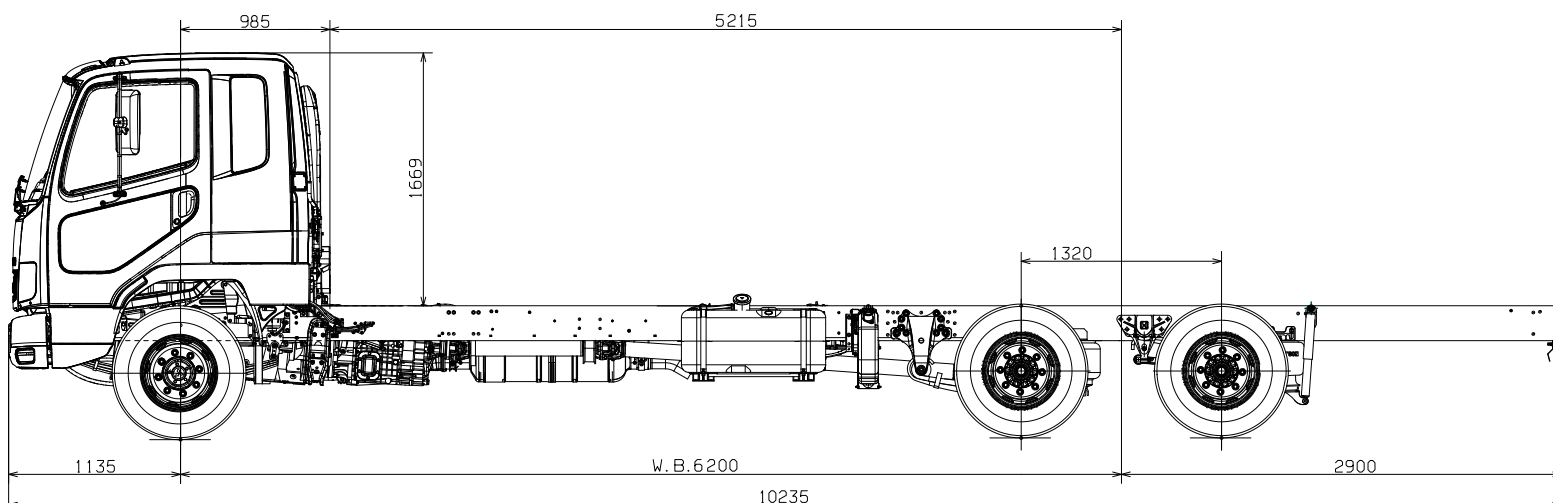

FIGHTER FU1828 – ‘M’ WHEELBASE

1000
UNIT: mm 20mm = 1m

Scale = 1:50 (20mm = 1 metre). This scale is accurate when used on the original spec sheet, be aware that enlarging these illustrations can alter the scale and cause incorrect measurements. Fuso New Zealand and its authorised dealers always recommend customers seek professional advice from independent sources before commencing any engineering activities.

A policy of continual improvement means that specifications detailed in this brochure are subject to change without notice. Contact your authorised Fuso dealer to confirm current specifications. Fuso is a registered trademark of Mitsubishi Fuso Truck & Bus Corporation. Copyright © Fuso NZ (2021)