

SHORT WHEELBASE

# FIGHTER FM1628

**EURO 5** • 4x2 • **MANUAL** OR **ALLISON AUTO**



**GVM:**  
16,000kg



**Power / Torque:**  
207kW / 802Nm



**Wheelbase:**  
4,280mm (H)

- 30,000km service intervals
- 6spd or 9spd transmission
- Isringhausen driver's seat
- 6.5T front axle
- 3yr / 200,000km Warranty (T&Cs inside)

# SPECIFICATIONS - FIGHTER FM1628 SWB

## MODEL

|            |       |      |             |             |
|------------|-------|------|-------------|-------------|
| 4x2 FM1628 | 6 SP. | MAN  | STEEL SUSP. | FM65FH2RFAH |
| 4x2 FM1628 | 9 SP. | MAN  | STEEL SUSP. | FM65FH2RFAK |
| 4x2 FM1628 | 6 SP. | AUTO | STEEL SUSP. | FM65FH2RFAM |

## WHEELBASE (mm)

|           |
|-----------|
| 4,280 (H) |
| 4,280 (H) |
| 4,280 (H) |

## GVM (kg) (optional)

|                 |
|-----------------|
| 16,000 (12,000) |
| 16,000 (12,000) |
| 16,000 (12,000) |

## GCM (kg)

|        |
|--------|
| 25,000 |
| 32,000 |
| 25,000 |

## ENGINE

|                            |  |
|----------------------------|--|
| Engine Version             | FUSO 6M60-9AT2 Diesel  |
| Configuration              | 6 Cyl. In-line OHC, 4-Valve  |
| Type                       | Variable Geometry Turbo Charged Air to Air Intercooler   |
| Displacement               | 7.5 litre (7545cc)   |
| Power ECE Nett             | 199kW @ 2500rpm  |
| Torque ECE Nett            | 785Nm @ 1100-2400rpm   |
| Power (JIS Gross)*         | 207kW (281ps) @ 2500rpm  |
| Torque (JIS Gross)*        | 802Nm(592lbft) @ 1100-2400rpm  |
| Maximum Engine Speed (rpm) | 2900   |
| Compression Ratio          | 16.0:1   |
| Cooling System/Oil Cooler  | Water cooled with Viscous fan, 23.0L capacity. Engine oil cooler   |
| Air Cleaner                | Paper Element Type with Restrictor Indicator. Vertical Intake Mounted on Clean Air Side (RH)               |
| Cold Start Preheat         | Standard   |
| Emission Control           | Selective Catalytic Reduction (SCR) After-Treatment System (BlueTec), Positive Crankcase Ventilation (PCV) |
| Emission Level             | Euro 5 (ADR 80/03)   |

\*Calculated

## 6M60-9AT2

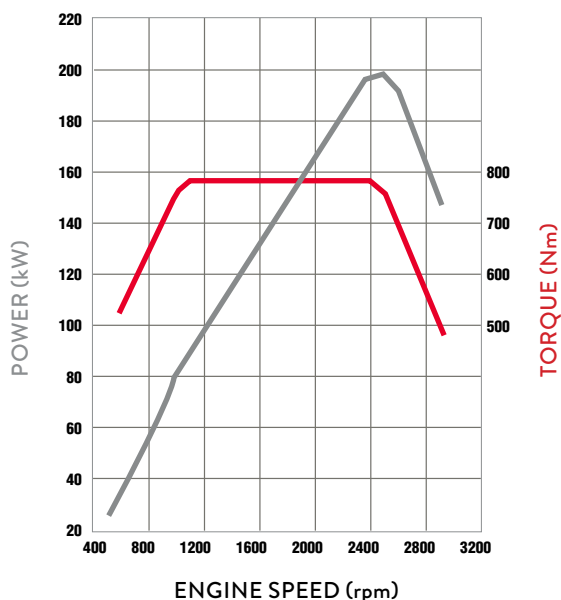

## FUEL

|                                   |   |
|-----------------------------------|---|
| Injection System                  | DENSO Common Rail System Electronically Controlled Direct Injection |
| Tank Type                         | Rectangular Steel Tank with Locking Cap                             |
| Fuel Capacity (L)                 | 200   |
| AdBlue Exhaust Fluid Capacity (L) | 40  |

## ELECTRICAL

|                       |                                |
|-----------------------|--------------------------------|
| Voltage               | 24V Negative Earth             |
| Alternator Capacity   | 24V-80 amp                     |
| Battery Specification | Heavy Duty 2 x 12V, 100Ah/20hr |
| Headlamp Type         | Halogen 2 x 70W/75W            |

## CLUTCH

|                         |                                 |
|-------------------------|---------------------------------|
|                         | Manual                          |
| Clutch Model            | FUSO C7M38                      |
| Type                    | Single Plate Cerametallic 380mm |
| Operation/Specification | Air Assisted Hydraulic          |

## TRANSMISSION

|   | 6 Speed  | 9 Speed   | Auto   |
|---|--|---|--|
| Version   | FUSO Manual M070S6-D   | Eaton Manual ES-11109 (Fuso Code M060S9)  | Allison Automatic MD3500 (M100A6)  |
| Type/Speeds                                       | 6 with Air Assisted Gearshift  | 9 Speed   | 6 Speed  |
| Features  | Synchromesh 2nd-6th  | Synchromesh 1L-4H   | Generation 5 Control Systems   |
| Ratios  | 1st: 8.064<br>2nd: 5.443<br>3rd: 3.064<br>4th: 1.824<br>5th: 1.321<br>6th: 1.000<br>Rev. 7.354 | Low Range<br>Low: 12.64<br>1st: 8.81<br>2nd: 6.55<br>3rd: 4.77<br>4th: 3.55<br>High Range<br>1st: 2.48<br>2nd: 1.85<br>3rd: 1.34<br>4th: 1.00<br>Rev: 13.21 | 1st: 4.593<br>2nd: 2.257<br>3rd: 1.535<br>4th: 1.000<br>5th 0.749<br>6th 0.651<br>Rev. 4.999 |
| PTO Opening                                       | LH Side  | LH Side / Rear  | 4 o'clock / 8 o'clock  |
| Torque Converter/Stall Torque Ratio (Auto model)  |  |   | TC415/2.35   |
| Automatic Transmission Fluid Cooling (Auto model) |  |   | 2 Chassis Mounted Coolers (LH & RH Side)   |

## PROPELLER SHAFT

|                 |                |         |
|-----------------|----------------|---------|
|                 | 6 Speed / Auto | 9 Speed |
| Type            | P10            | P12     |
| Universal Joint | Needle Roller  |         |

## FRONT AXLE

|                             |                     |
|-----------------------------|---------------------|
| Axle                        | FUSO F650T "I" Beam |
| Design Capacity (kg)        | 6,500               |
| Max Operating Capacity (kg) | 6,500               |

## FRONT SUSPENSION

|           |  |
|-----------|--|
| Type      | Taper Leaf spring with Double Acting Shock Absorbers |
| Size (mm) | 1,400 x 80   |

# SPECIFICATIONS - FIGHTER FM1628 SWB

## REAR AXLE

|                             | 6 Speed                       | 9 Speed                        | Auto    |
|-----------------------------|-------------------------------|--------------------------------|---------|
| Axle                        | FUSO D8H Full Floating Hypoid | FUSO D10H Full Floating Hypoid |         |
| Design Capacity (kg)        | 10,200                        | 10,800                         |         |
| Max Operating Capacity (kg) | 10,000                        | 10,000                         |         |
| Ratio                       | 5.142:1                       | 4.625:1                        | 6.666:1 |

## REAR SUSPENSION

|                         |                   |
|-------------------------|-------------------|
| Type                    | Steel Suspension  |
| Details                 | Multi Leaf spring |
| Size Main Leaves (mm)   | 1,400 x 80        |
| Size Helper Leaves (mm) | 960 x 80          |

## STEERING

|                |   |
|----------------|---|
| Power Assisted | Tilt/Telescopic Adjustable Steering Wheel |
|----------------|---|

## BRAKES

|                        |  |
|------------------------|--|
| Type                   | Full Air, Dual Circuit, FUSO Taper Roller, Automatic Brake adjustment, ABS |
| ASR (Traction Control) | Yes  |
| Size Front / Rear (mm) | 410 x 150 / 410 x 200  |
| Park Brake             | Rear Wheel Spring Actuated   |
| Auxiliary              | Exhaust Brake  |
| Compressor             | Water Cooled, 340cc Single Cylinder with air dryer                         |

## WHEELS AND TYRES

|                    |                            |
|--------------------|----------------------------|
| Wheel Type         | 7, Single Piece Steel Disc |
| Wheel Size         | 22.5 x 8.25DC-165-13t      |
| Wheel Stud Pattern | 10 stud 335mm PCD          |
| Tyre Size All      | 11R22.5                    |
| Spare Tyre Carrier | Provided                   |

## CHASSIS

|            |                             |
|------------|-----------------------------|
| Type       | Reinforced Parallel Channel |
| Size (mm)  | 280 x 90 x 8.0              |
| Width (mm) | 841                         |

Refer to the bodybuilders guidelines on the Fuso website ([www.fuso.co.nz](http://www.fuso.co.nz)) before mounting a body or modifying the chassis

## INSTRUMENTS

|                            |  |
|----------------------------|--|
| Gauges                     | Speedometer with Odometer, Tachometer; Air Pressure (2), Fuel Level; Water Temperature |
| Colour Information Display | Fuel Consumption; Service Indicators Hour Meter and Tripmeter                          |

## STANDARD FEATURES

|                         |  |
|-------------------------|--|
| Airbag                  | Driver's Air Bag and Seat Belt Pre-tensioner |
| Hill Start System       | Yes (not available on auto model)            |
| Cab Cooling and Heating | Air Conditioner / Heater / Demister          |

## KERB WEIGHTS AND MAX AXLE LOADS (kg)

| Model                             |                | Vehicle Ratings** |        | Max Axle Loadings** |        | Kerb Weights* |       |       |
|-----------------------------------|----------------|-------------------|--------|---------------------|--------|---------------|-------|-------|
|                                   |                | GVM               | GCM    | Front               | Rear   | Front         | Rear  | Total |
| 4x2 FM1628 6 Sp. Man Steel Susp.  | FM65FH2RFAH    | 16,000            | 25,000 | 6,500               | 10,000 | 2,840         | 1,870 | 4,710 |
| 4x2 FM1628 9 Sp. Man Steel Susp.  | FM65FH2RFAK    | 16,000            | 32,000 | 6,500               | 10,000 | 2,925         | 1,925 | 4,850 |
| 4x2 FM1628 6 Sp. Auto Steel Susp. | FM65FH2RFAM    | 16,000            | 25,000 | 6,500               | 10,000 | 2,965         | 1,960 | 4,925 |
| 4x2 FM1228 6 Sp. Man Steel Susp.  | FM65FH2RFAH(D) | 12,000            | 25,000 | 6,500               | 10,000 | 2,840         | 1,870 | 4,710 |
| 4x2 FM1228 9 Sp. Man Steel Susp.  | FM65FH2RFAK(D) | 12,000            | 32,000 | 6,500               | 10,000 | 2,925         | 1,925 | 4,850 |
| 4x2 FM1228 6 Sp. Auto Steel Susp. | FM65FH2RFAM(D) | 12,000            | 25,000 | 6,500               | 10,000 | 2,965         | 1,960 | 4,925 |

\* Weights (est.) includes 10L fuel and spare wheel and are subject to 2.5% variation (+/-) \*\* Vehicle ratings and max axle loadings may be limited by local regulations.

## STANDARD FEATURES

|                 |  |
|-----------------|--|
| Accessory Power | 24V Accessory Power Outlet / Cigar Lighter   |
| Audio           | AM/FM + USB + Bluetooth Hands Free   |
| Driving         | Central Locking, Electric Windows, Cruise Control, LH Transom Window, Cup Holders (4), Rear Quarter Glass, Fluorescent Cabin Lamp and Interior Reading Lamps, Engine Idle Speed Control                    |
| Storage         | Centre Seat Storage Console, Rear Bunk Storage Pocket, Dash Storage Tray 2 DIN Glove Compartment, 1 Single and 1 Double DIN Slot for Accessories, Overhead Storage Pocket with Lid, RH Door Storage Pocket |
| Cab: External   | Roof Mounting Points (max. static load 70kg) Front End-Outline Marker Lamps  |
| Chassis         | Chassis Mounted Tool Box Reverse Warning Buzzer  |

## CAB FEATURES

|                     |   |
|---------------------|---|
| Type                | All Steel Forward Control, Manual Tilt 44 deg.  |
| Mounting            | Hydroelastic Susp. 4 Point  |
| Colour              | Natural White (W31)   |
| Interior            | Fully Trimmed   |
| Windscreen          | Laminated Tinted  |
| Windscreen Wipers   | 2 Speed + Intermittent Cycle with Integrated Washer Nozzles   |
| Door                | 90 degree Opening Angle   |
| Rear Vision Mirrors | Remote Control / Heated + Convex Spotter (Both Sides)   |
| Seating Capacity    | 3   |
| Seat Belts          | Lap Sash Belts for Outside Seats, Lap Belt for Centre   |
| Seat (driver)       | ISRI Air Susp. + Auto Levelling, Height, Tilt, Lumbar, Bolster and Dampening Adjust, Integral Headrest, Fabric Trim                         |
| Seats (passenger)   | Centre: Low Back with Fabric Trim and Forward Folding Far Passenger: Fixed Base with Reclining Seat Back, Integral Headrest and Fabric Trim |

## OPTIONS

6.2" Touchscreen Media Unit AM/FM/DAB + USB + AUX, Apple CarPlay and Android Auto, Wi-Fi enabled for internet radio, Bluetooth, 32GB storage capacity, HD Reverse Camera included  
Additional cameras for Media Unit (up to 4)  
Truck Specific GPS Navigation  
Reverse Sensors  
Tyre Pressure Monitoring System (up to 36 tyres)  
Wireless Phone Charging Pocket  
Extended Warranty: Additional 2yrs / 100,000km

## SERVICE INTERVALS

**30,000km full service / 15,000km safety inspection**  
30,000km full service intervals, depending on application/use.  
15,000km safety inspection, with greasing, required for reliability and to maintain warranty cover.

## WARRANTY

**3 years / 200,000km**  
Tipper body covered by 12mth / unlimited km warranty.  
Refer to terms and conditions in the FUSO warranty booklet for full details.

# SPECIFICATIONS - FIGHTER FM1628 SWB

## PERFORMANCE

|  | 6 Speed | 9 Speed | Auto  |
|--|---------|---------|-------|
| Turning Circle (kerb to kerb - metres)   | 14.6    | 14.6    | 14.6  |
| Electronically Speed Limited to (km/hr): | 100     | 100     | 100   |
| Engine Speed (rpm) at 90km/hr (top gear) | 2,430   | 2,185   | 2,050 |
| Gradeability at Rated GVM (theoretical)* | 37%     | 54%     | 69%   |
| Gradeability at Rated GCM (theoretical)* | 22%     | 24%     | 38%   |

\*Theoretical performance only. Actual performance may vary under different conditions

## DIMENSIONS (MM)

|                           | H Wheelbase |
|---------------------------|-------------|
| Wheelbase                 | 4,280       |
| Length Overall            | 7,455       |
| Height Overall            | 2,680       |
| Width Overall             | 2,470       |
| Width Rear Axle           | 2,470       |
| Width Front Track         | 1,925       |
| Width Rear Track          | 1,850       |
| Width Frame               | 841         |
| Height Frame at Rear Axle | 1,075       |

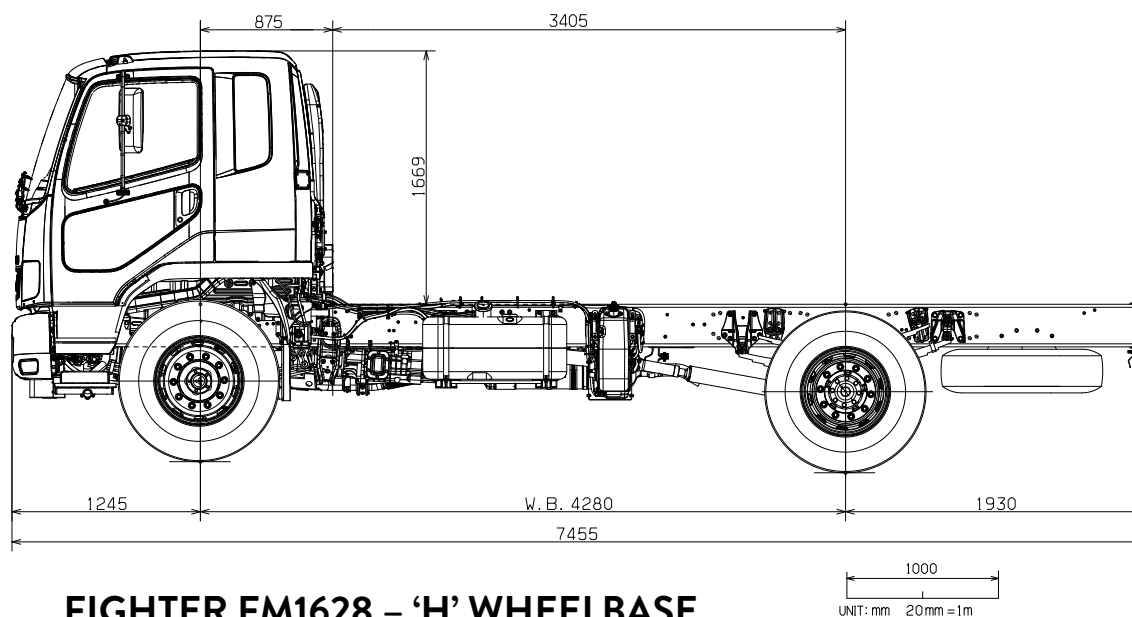

**FIGHTER FM1628 – 'H' WHEELBASE**

1000  
UNIT: mm 20mm=1m

Scale = 1:50 (20mm = 1 metre). This scale is accurate when used on the original spec sheet, be aware that enlarging these illustrations can alter the scale and cause incorrect measurements. Fuso New Zealand and its authorised dealers always recommend customers seek professional advice from independent sources before commencing any engineering activities.

A policy of continual improvement means that specifications detailed in this brochure are subject to change without notice. Contact your authorised Fuso dealer to confirm current specifications. Fuso is a registered trademark of Mitsubishi Fuso Truck & Bus Corporation. Copyright © Fuso NZ (2021)