

TIPPER

CANTER 816

DUONIC AMT OR MANUAL

2021 MODEL
ADVANCED
SAFETY
SYSTEMS



GVM:
7,500kg



Power/Torque:
110kW/370Nm



Wheelbase:
2,800mm (C)

- Electronic Brake System **NEW**
- Electronic Stability Control **NEW**
- Active Emergency Braking System **NEW**
- Lane Departure Warning System **NEW**
- 3yr/100,000km warranty
- Larger tray with 3-way tailgate **NEW**

SPECIFICATIONS - CANTER 816 TIPPER

MODEL

4x2 816	WIDE CAB TIPPER	6 SP.	AMT	FEC81CR3SFBC(T)
4x2 816	WIDE CAB TIPPER	5 SP.	MAN	FEC81CR4SFBC(T)

WHEELBASE (mm)

2,800 (C)
2,800 (C)

GVM (kg) (optional)

7,500 (5,995)
7,500 (5,995)

GCM (kg) (optional)

11,000 (9,500)
11,000 (9,500)

ENGINE

Engine Version	FUSO 4P10-T4 Diesel
Configuration	4 Cyl. In-line DOHC, 4-Valve
Type	Variable Geometry Turbo Charged Air to Air Intercooled
Displacement	3 litre (2,998cc)
Power (DIN)	110kW @ 2840~3500rpm
Torque (DIN)	370Nm @ 1350~2840rpm
Maximum Engine Speed (rpm)	4100
Compression Ratio	17.5:1
Cooling System/Oil Cooler	Water cooled with Viscous fan, 13.7L capacity. Engine oil cooler
Air Cleaner	Paper Element Type with Restrictor Indicator. Vertical Intake Mounted on Clean Air Side (RH)
Cold Start Preheat	Standard
Emission Control	Diesel Particulate Filter (DPF) Exhaust Dash Display DPF Status 0~9 (Empty~Full) Parked Regeneration possible from 7~9
Emission Level	EURO 5 (ADR 80/03) and EEV rated (Enhanced Environmentally-Friendly Vehicle)

4P10-T4

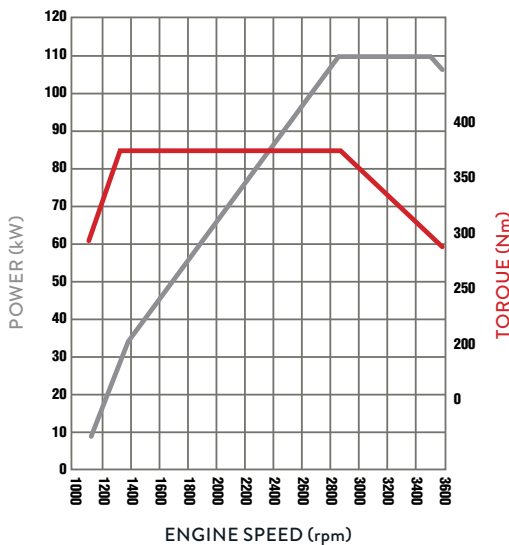

FUEL

Injection System	Bosch Common Rail Direct Injection Bosch Piezo Technology Injectors
Tank Type	Rectangular Steel Tank with Locking Cap
Fuel Capacity (L)	100
Filtration	Filter with Water Separator and Indicator Sensor

ELECTRICAL

Voltage	12V Negative Earth
Alternator Capacity	12V-110 amp
Battery Specification	Heavy Duty 115D31L x 2
Headlamp Type	Halogen 2 x 55W/60W
Fog lamp in bumper	Standard

CLUTCH

	DUONIC AMT	Manual
Clutch Model	DUONIC Automated Manual (no clutch pedal)	FUSO C4W30
Type	Dual Clutch (Wet Multi-plate)	Single Dry Plate, Direct Hydraulic Type, 300mm

TRANSMISSION

Version	DUONIC	Manual
	FUSO DUONIC M038S6	FUSO M038S5
Type/Speeds	6 Speed Automated Manual with Auto and Manual Modes	5 Speed with In-Dash Gearshift Lever
Features	Virtually Instant Gear Changes In-Dash Gear Lever with Park Brake Position ECO Mode to Minimise Fuel Usage	Synchromesh 2nd-5th
Ratios	1st: 5.397 2nd: 3.788 3rd: 2.310 4th: 1.474	5th: 1.000 6th: 0.701 Rev. 5.397
PTO Opening	LH Side Direct Connection Pump	1st: 5.494 2nd: 3.193 3rd: 1.689 4th: 1.000 5th: 0.723 Rev. 4.494
		LH Side Direct Connection Pump

FRONT AXLE

Axle	FUSO F350T "I" Beam
Design Capacity (kg)	3,100
Max Operating Capacity (kg)	3,100

FRONT SUSPENSION

Type	Multi Leaf with Stabiliser Bar and Double Acting Shock Absorbers
Size (mm)	1,150 x 70

REAR AXLE

Type	FUSO RO35T Full Floating Banjo Type with Positive Locking Limited Slip Differential (LSD)
Ratio	DUONIC 5.714:1 Manual 5.285:1
Design Capacity (kg)	6,000
Max Operating Capacity (kg)	6,000

REAR SUSPENSION

Type	Steel Suspension
Details	Multi Leaf with Stabiliser Bar and Double Acting Shock Absorbers
Size Main Leaves (mm)	1,250 x 70
Size Helper Leaves (mm)	880 x 70

STEERING

Power Assisted	Tilt/Telescopic Adjustable Steering Wheel
----------------	---

BRAKES

Type	Hydraulic Dual Circuit with Front and Rear Discs Twin Caliper Front and Rear
Size Front/Rear (mm)	310 x 40
Features	ABS + EBD + EBS Exhaust Brake Brake Priority System
Park Brake	Transmission Mounted

SPECIFICATIONS - CANTER 816 TIPPER

2021 MODEL
ADVANCED
SAFETY
SYSTEMS

WHEELS AND TYRES

Wheel Size	17.5 x 6.0-127
Tyre Size Front/Rear	215/75R17.5 / 215/75R17.5 Traction
Spare Tyre Carrier	Yes. LHS of chassis

CHASSIS

Size (mm)	212 x 65 x 6
-----------	--------------

Refer to the bodybuilders guidelines on the Fuso website (www.fuso.co.nz) before mounting a body or modifying the chassis

INSTRUMENTS

Gauges	Speedometer with Odometer; Tachometer; Fuel Level; Water Temperature
Colour Information Display	Fuel Consumption DPF Bar Chart from 1~9 Water Temperature Maintenance Reminder System Date and Time Tripmeters x 2

STANDARD FEATURES

Cab Cooling and Heating	Air Conditioner / Heater / Demister
Accessory Power	12V Accessory Power Outlet / Cigar Lighter
Driving	Keyless Central Locking Electric Windows
Radio	AM/FM + CD + USB + Bluetooth
Storage	Dual Overhead Storage Pockets In-Dash Centre Document Storage Door Storage Pockets Lockable Glove Box

CAB FEATURES

Type	All Steel Forward Control Manual Tilt
Mounting	Hydroelastic 4 Point
Colour	Natural White (W31)
Interior	Fully Trimmed cab with vinyl floor covering
Seating Capacity	3
Seat (driver)	Heavy Duty Suspended with LH Arm Rest, Adjustable Lumbar Support and Weight Adjustment.
Seats (passenger)	Flat Folding, 2 Passenger Bench

SERVICE INTERVALS

30,000km full service / 15,000km safety inspection
30,000km full service intervals, depending on application/use.
15,000km safety inspection, with greasing, required to maintain warranty cover and ensure optimum performance.

WARRANTY

3 years / 100,000km
All tipper and body equipment covered by 12mth/unlimited km warranty.
Refer to terms and conditions in the FUSO warranty booklet for full details.

SAFETY FEATURES

ACTIVE SAFETY FEATURES

Electronic Brake System (EBS)	Yes	NEW
Electronic Stability Control (ESC)	Yes	NEW
Active Emergency Braking System (AEBS)	Yes	NEW
Lane Departure Warning System (LDWS)	Yes	NEW

CAB

Structure	ECE R-29 Reinforced Cab Side Intrusion Bar
Airbags	Driver's (steering wheel) Passenger's (dashboard) NEW
Seatbelts	ELR 3-Point (+ height-adjustable with pre tensioner for driver) Lap Belt (centre passenger)
Driver's Seat	Spring-suspended
Steering Wheel	Energy-absorbing Adjustable (height and reach)
Rearview Mirrors	Heated
Fog Lamps	Yes
Keyless Central Locking	Yes

CHASSIS

Speed Limiter	Yes (activated and adjustable by FUSO dealer)
Cruise Control	Duonic models
Anti-Lock Braking System (ABS)	Yes
Anti-Slip Regulator (ASR)	Yes
Electronic Brake Force Distribution (EBD)	Yes
Disc Brakes	Auto-Adjusting, 4 Wheel Dual Caliper
Brake Priority System	Yes
Exhaust Brake	Yes
Hill Start Assist	Yes (adjustable engagement on manual transmission)
Reverse Warning Buzzer	Yes
Anti Roll Bar	Yes
Brake Wear Indicator	Yes

OPTIONS

7" Touchscreen Media Unit	AM/FM/DAB + USB + AUX, Apple CarPlay and Android Auto, Wi-Fi enabled for Internet Radio, Bluetooth, 32GB capacity storage, HD Reverse Camera included †
---------------------------	---

† Up to 4 additional Display Cameras

Truck Specific GPS Navigation	
Reversing Sensors	
Tyre Pressure Monitoring System	
Wireless Phone Charge Pocket	
Extended Warranty	Additional 2yrs / 100,000km

KERB WEIGHTS AND MAX AXLE LOADS (kg)

Model		Vehicle Ratings**		Max Axle Loadings**		Kerb Weights*		
		GVM	GCM	Front	Rear	Front	Rear	Total
4x2 816 Wide Cab Tipper 6 Sp. AMT	FEC81CR3SFBC(T)	7,500	11,000	3,100	6,000	1,715	1,560	3,275
4x2 816 Wide Cab Tipper 5 Sp. MAN	FEC81CR4SFBC(T)	7,500	11,000	3,100	6,000	1,705	1,560	3,265
4x2 616 Wide Cab Tipper 6 Sp. AMT	FEC81CR3SFBC(DT)	5,995	9,500	3,100	6,000	1,715	1,560	3,275
4x2 616 Wide Cab Tipper 5 Sp. MAN	FEC81CR4SFBC(DT)	5,995	9,500	3,100	6,000	1,705	1,560	3,265

* Weights (est.) includes 10L fuel and spare wheel and are subject to 2.5% variation (+/-) ** Vehicle ratings and max axle loadings may be limited by local regulations.

SPECIFICATIONS - CANTER 816 TIPPER

PERFORMANCE

	DUONIC AMT	Manual
Turning Circle (kerb to kerb - metres)	10.4	10.4
Road Speed (km/h) at Max Engine Speed	127	130
Engine Speed (rpm) at 90km/hr (top gear)	2535	2420
Gradeability at Rated 7500kg GVM (theoretical)*	40%	37%
Notes	*This is theoretical performance only. Actual performance may vary under different conditions	

DIMENSIONS (mm)

Wheelbase	2,800
Length Overall	5,415
Height Overall	2,180
Width Overall	2,255
Width Rear Axle	2,190
Width Front Track	1,665
Width Rear Track	1,670
Width Frame	850

REAR BODY

Type:	ShinMayawa Tipper Body
Body Capacity (m ³):	2.6 NEW
Inside Body Dimensions (mm):	
Length x Width x Height	3,400 x 2,080 x 370
Floor Height From Ground to Rear Deck Floor	1,130
Thickness : Floor	3.2
Front and Side Panel	2.3
Tail Panel	2.3
Sides and Tailgate Operation	Drop down sides with three-way tailgate hinging at the top, bottom and side NEW
Tipping Mechanism:	Under body-hydraulic cylinder with link
Tipping Performance: Tip Angle (deg)	60
Lifting Time (sec)	20
Lowering Time (sec)	20

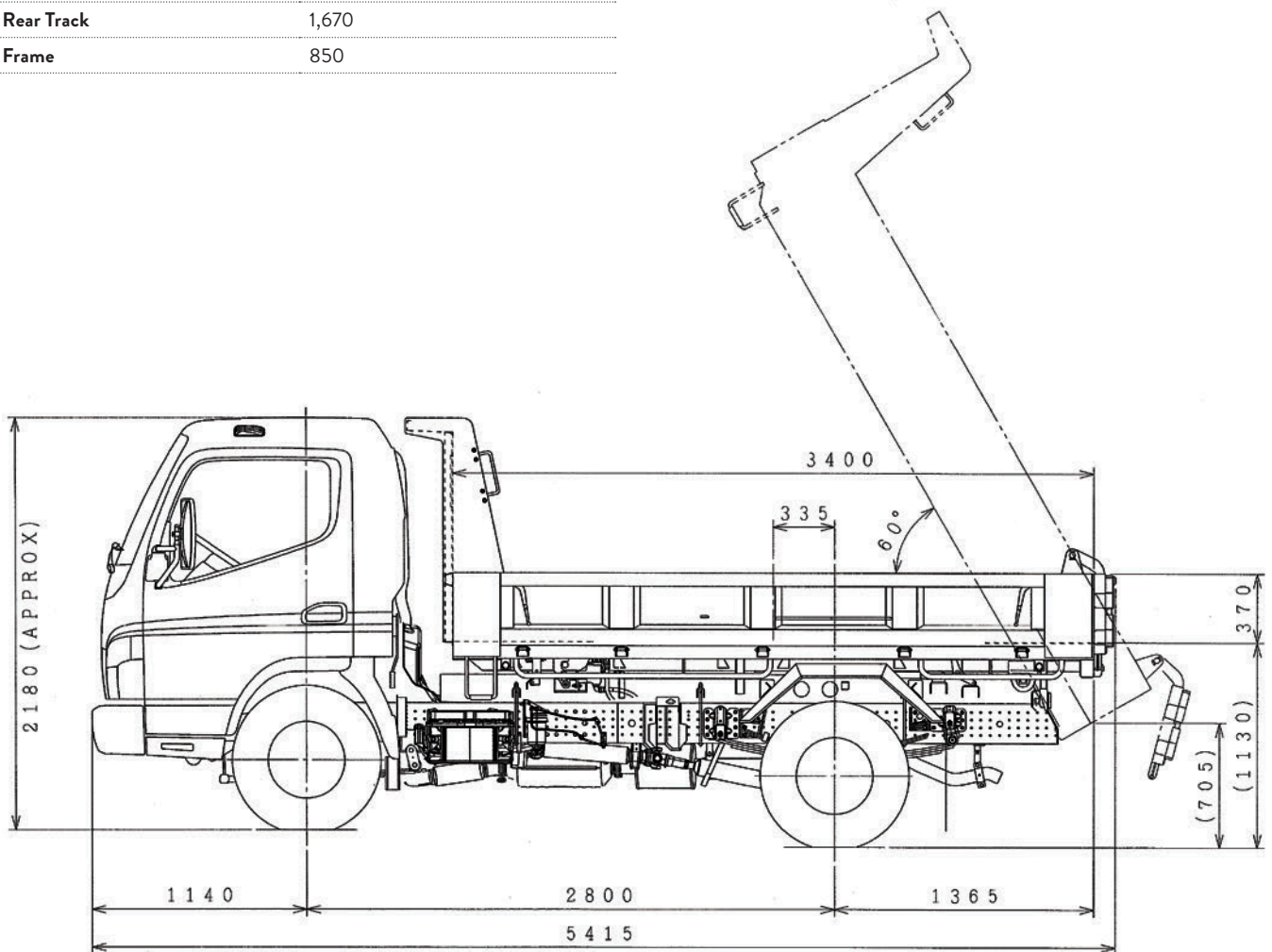

CANTER 816 TIPPER – 'C' WHEELBASE

A policy of continual improvement means that specifications detailed in this brochure are subject to change without notice. Contact your authorised Fuso dealer to confirm current specifications. Fuso is a registered trademark of Mitsubishi Fuso Truck & Bus Corporation. Copyright © Fuso NZ (2021)