

SHORT WHEELBASE

FIGHTER FK1025

EURO 5 • 4x2 • **MANUAL**



GVM:
10,600kg



Power / Torque:
184kW / 761Nm



Wheelbase:
4,270mm (H) / 4,870mm (K)

- 30,000km service intervals
- High-torque engine
- Isringhausen driver's seat
- Park brake on rear axle

SPECIFICATIONS - FIGHTER FK1025 SWB

MODEL

4x2 FK1025	6 SP.	MAN	STEEL SUSP.	FK61FH1RFAC
4x2 FK1025	6 SP.	MAN	STEEL SUSP.	FK61FK1RFAC

WHEELBASE (mm)

4,270 (H)
4,870 (K)

GVM (kg)

10,600
10,600

GCM (kg)

20,000
20,000

ENGINE

Engine Version	FUSO 6M60-9AT1 Diesel
Configuration	6 Cyl. In-line OHC, 4-Valve
Type	Variable Geometry Turbo Charged Air to Air Intercooler
Displacement	7.5 litre (7545cc)
Power ECE Nett	177kW @ 2500rpm
Torque ECE Nett	745Nm @ 1400rpm
Power (JIS Gross)*	184kW (250ps) @ 2500rpm
Torque (JIS Gross)*	761Nm (561lb/ft) @ 1400rpm
Maximum Engine Speed (rpm)	2900
Compression Ratio	16.0:1
Cooling System/Oil Cooler	Water cooled with Viscous fan, 23.0L capacity. Engine oil cooler
Air Cleaner	Paper Element Type with Restrictor Indicator. Vertical Intake Mounted on Clean Air Side (RH)
Cold Start Preheat	Standard
Emission Control	Selective Catalytic Reduction (SCR) after-treatment system (BlueTec), Positive Crankcase Ventilation (PCV)
Emission Level	EURO 5 (ADR 80/03)

*Calculated

6M60-9AT1

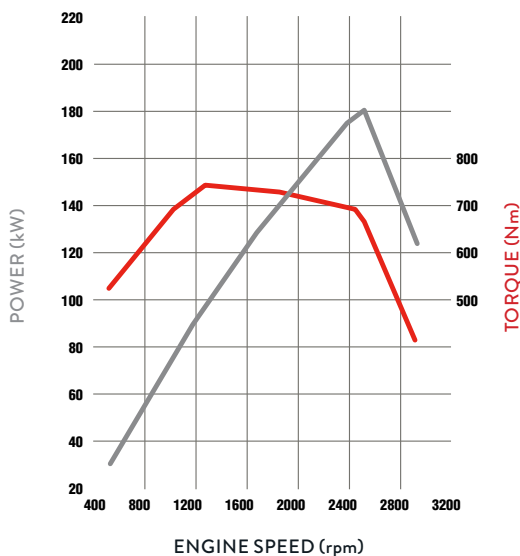

FUEL

Injection System	DENSO Common Rail System Electronically Controlled Direct Injection
Tank Type	Rectangular Steel Tank with Locking Cap
Fuel Capacity (L)	200
AdBlue Exhaust Fluid Capacity (L)	25

ELECTRICAL

Voltage	24V Negative Earth
Alternator Capacity	24V-80 amp
Battery Specification	Heavy Duty 2 x 12V, 100Ah/20hr
Headlamp Type	Halogen 2 x 70W/75W

CLUTCH

Clutch Model	FUSO C7M38
Type	Single Plate Cerametallic 380mm
Operation/Specification	Air Assisted Hydraulic

TRANSMISSION

Version	FUSO Manual M070S6-OD	
Type/Speeds	6 with Air Assisted Gearshift	
Features	Synchromesh 2nd-6th	
Ratios	1st: 6.807 2nd: 4.172 3rd: 2.396 4th: 1.504	5th: 1.000 6th: 0.774 Rev. 6.807
PTO Opening	LH Side	

PROPELLER SHAFT

Type	P10
Universal Joint	Needle Roller

FRONT AXLE

Axle	FUSO F400T "I" Beam
Design Capacity (kg)	3,800
Max Operating Capacity (kg)	3,800

FRONT SUSPENSION

Type	Taper Leaf Spring with Stabiliser Bar and Double Acting Shock Absorbers
Size (mm)	1,300 x 70

REAR AXLE

Axle	FUSO D052 Full Floating Hypoid
Design Capacity (kg)	9,500
Max Operating Capacity (kg)	7,000
Ratio	4.444:1

REAR SUSPENSION

Type	Steel Suspension
Details	Multi Leaf Spring with Stabiliser Bar
Size Main Leaves (mm)	1,300 x 70
Size Helper Leaves (mm)	900 x 70

STEERING

Power Assisted	Tilt/Telescopic Adjustable Steering Wheel
----------------	---

SPECIFICATIONS - FIGHTER FK1025 SWB

BRAKES

Type	Air Actuated Hydraulic Dual Circuit with Automatic Brake Adjustment and ABS
ASR (Traction Control)	N/A
Size Front / Rear (mm)	320 x 120 / 320 x 140
Park Brake	Rear Wheel Spring Actuated
Auxiliary	Exhaust Brake
Compressor	Water Cooled, 340cc Single Cylinder with Air Dryer

WHEELS AND TYRES

Wheel Type	7, Single Piece Disc
Wheel Size	17.5x6.75DC-131-10t
Wheel Stud Pattern	6 stud 222.25mm PCD
Tyre Size All	235/75R17.5
Spare Tyre Carrier	Provided

CHASSIS

Type	Parallel Channel
Size (mm)	228 x 80 x 7.0
Width (mm)	842
Refer to the bodybuilders guidelines on the Fuso website (www.fuso.co.nz) before mounting a body or modifying the chassis	

INSTRUMENTS

Gauges	Speedometer with Odometer, Tachometer, Air Pressure (2), Fuel Level, Water Temperature
Colour Information Display	Fuel Consumption, Service Indicators, Hour Meter and Tripmeter

STANDARD FEATURES

Airbag	Driver's Air Bag and Seat Belt Pre-tensioner
Hill Start System	Yes (Not available on auto model)
Cab Cooling and Heating	Air Conditioner/Heater/Demister
Accessory Power	24V Accessory Power Outlet/Cigar Lighter
Audio	AM/FM + USB + Bluetooth Hands Free
Driving	Keyless Central Locking, Electric Windows, Cruise Control, LH Transom Window, Cup Holders (4), Rear Quarter Glass, Fluorescent Cabin Lamp and Interior Reading Lamps, Engine Idle Speed Control
Storage	Centre Seat Storage Console, Rear Bunk Storage Pocket, Dash Storage Tray 2 DIN Glove Compartment, 1 Single and 1 Double DIN Slot for Accessories, Overhead Storage Pocket with Lid, RH Door Storage Pocket
Cab: External	Roof Mounting Points (max. static load 70kg) Front End-Outline Marker Lamps
Chassis	Chassis Mounted Tool Box Reverse Warning Buzzer

CAB FEATURES

Type	All Steel Forward Control Manual Tilt 44 deg.
Mounting	Hydroelastic Susp. 4 Point
Colour	Natural White (W31)
Interior	Fully Trimmed
Windscreen	Laminated Tinted
Windscreen Wipers	2 Speed + Intermittent Cycle with Integrated Washer Nozzles
Door	90 degree Opening Angle
Rear Vision Mirrors	Remote / Heated with Convex Spotter (Both Sides)
Seating Capacity	3
Seat Belts	2 ELR Lap Sash, 1 Lap
Seat (driver)	ISRI Air Suspension with Auto Levelling, Height, Tilt, Lumbar, bolster and Dampening Adjustment, Integral Headrest and Fabric Trim
Seats (passenger)	Centre: Low Back with Fabric Trim and forward folding, LH Passenger: Fixed Base with Reclining Seat Back, Integral Headrest and Fabric Trim

SERVICE INTERVALS

30,000km full service / 15,000km safety inspection
30,000km full service intervals, depending on application/use.
15,000km safety inspection, with greasing, required to maintain warranty cover and ensure optimum performance.

WARRANTY

3 years / 150,000km
Refer to terms and conditions in the FUSO warranty booklet for full details.

OPTIONS

6.2" Touchscreen Media Unit AM/FM/DAB + USB + AUX,
Apple CarPlay and Android Auto, Wi-Fi enabled for internet radio,
Bluetooth, 32GB storage capacity, HD Reverse Camera included
Additional cameras for Media Unit (up to 4)
Truck Specific GPS Navigation
Reverse Sensors
Tyre Pressure Monitoring System (up to 36 tyres)
Wireless Phone Charging Pocket
Extended Warranty: Additional 2yrs / 150,000km

PERFORMANCE

Turning Circle (kerb to kerb - metres)	H = 13.8 K = 15.6
Electronically Speed Limited to (km/h):	100km/hr
Engine Speed (rpm) at 90km/hr (top gear)	2090
Gradeability at Rated GVM (theoretical)*	54%
Gradeability at Rated GCM (theoretical)*	26%

*Theoretical performance only. Actual performance may vary under different conditions

KERB WEIGHTS AND MAX AXLE LOADS (kg)

Model		Vehicle Ratings**		Max Axle Loadings**		Kerb Weights*		
		GVM	GCM	Front	Rear	Front	Rear	Total
4x2 FK1025 6 Sp. Man Steel Susp.	FK61FH1RFAC	10,600	20,000	3,800	7,000	2,230	1,280	3,510
4x2 FK1025 6 Sp. Man Steel Susp.	FK61FK1RFAC	10,600	20,000	3,800	7,000	2,220	1,310	3,530

* Weights (est.) includes 10L fuel and spare wheel and are subject to 2.5% variation (+/-)

** Vehicle ratings and max axle loadings may be limited by local regulations.

SPECIFICATIONS - FIGHTER FK1025 SWB

DIMENSIONS (mm)

	H Wheelbase	K Wheelbase	Width Rear Axle	2,175	2,175
Wheelbase	4,270	4,870	Width Front Track	1,810	1,810
Length Overall	7,220	8,095	Width Rear Track	1,665	1,665
Height Overall	2,465	2,465	Width Frame	842	842
Width Overall	2,175	2,175	Height Frame at Rear Axle	862	861

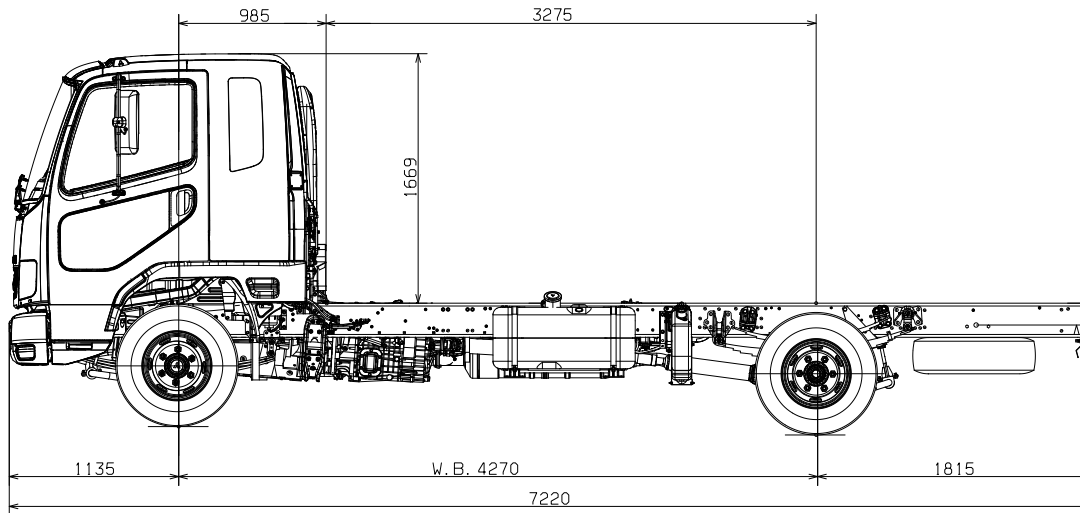

FIGHTER FK1025 – 'H' WHEELBASE

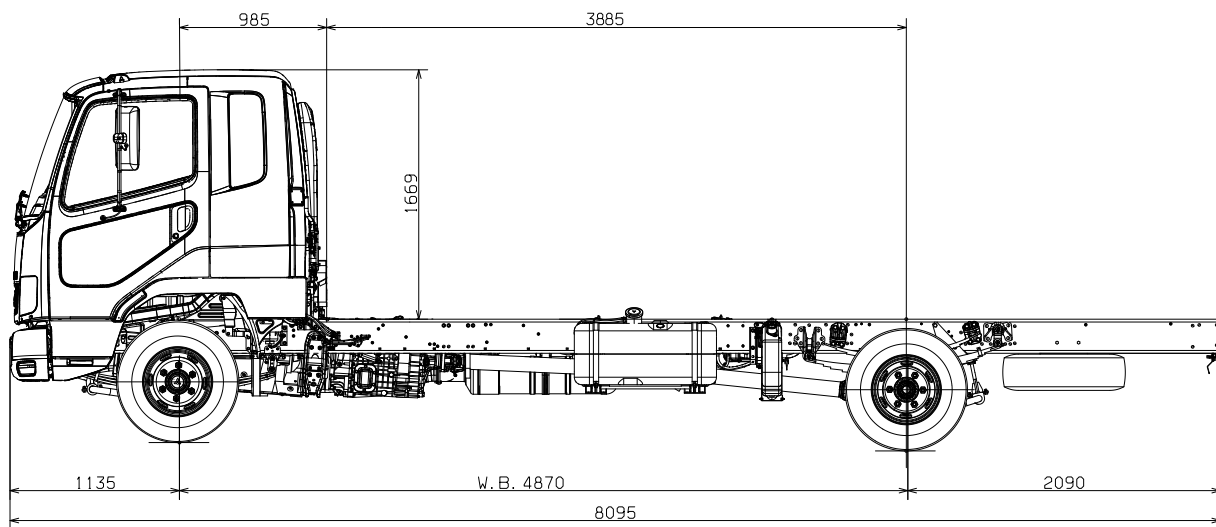

FIGHTER FK1025 – 'K' WHEELBASE

Scale = 1:50 (20mm = 1 metre). This scale is accurate when used on the original spec sheet, be aware that enlarging these illustrations can alter the scale and cause incorrect measurements. Fuso New Zealand and its authorised dealers always recommend customers seek professional advice from independent sources before commencing any engineering activities.

A policy of continual improvement means that specifications detailed in this brochure are subject to change without notice. Contact your authorised Fuso dealer to confirm current specifications. Fuso is a registered trademark of Mitsubishi Fuso Truck & Bus Corporation. Copyright © Fuso NZ (2021)