

CITY CREW CAB

CANTER 516

DUONIC AMT



GVM:
4,983kg



Power/Torque:
110kW/370Nm



Wheelbase:
3,400mm (E)

- 30,000km service intervals
- Six seats
- Car licence
- Independent front suspension

SPECIFICATIONS - CANTER 516 CITY CREW CAB

MODEL

4x2 516 CITY CREW CAB 6 SP. AMT FEA21ER3WFAC

WHEELBASE (mm)

3,400 (E)

GVM (kg)

4,983

GCM (kg)

8,483

ENGINE

Engine Version	FUSO 4P10-T4 Euro 5 Diesel
Configuration	4 Cyl. In-line DOHC, 4-Valve
Type	Variable Geometry Turbo Charged Air to Air Intercooled
Displacement	3 litre (2998cc)
Power (DIN)	110kW @ 2840~3500rpm
Torque (DIN)	370Nm @ 1350~2840rpm
Maximum Engine Speed	4100rpm
Compression Ratio	17.5:1
Cooling System / Oil Cooler	Water cooled with Viscous fan, 14.1L capacity. Engine oil cooler
Air Cleaner	Paper Element Type with Restrictor Indicator. Vertical Intake Mounted on Clean Air Side (RH)
Emission Control	Diesel Particulate Filter (DPF) Exhaust Dash Display DPF Status 0~9 (Empty~Full) Parked Regeneration possible from 7~9
Emission Level	EURO 5 (ADR 80/03) and EEV rated (Enhanced Environmentally-Friendly Vehicle)

4P10-T4

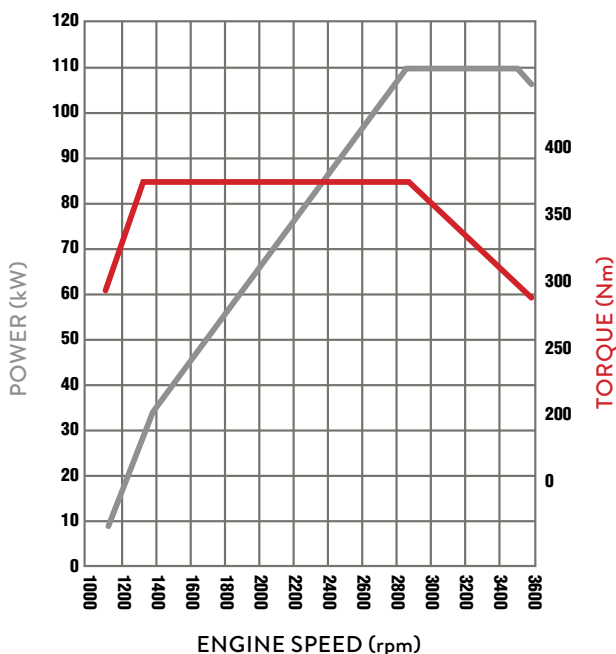

FUEL

Injection System	Bosch Common Rail Direct Injection Bosch Piezo Technology Injectors
Tank Type	Rectangular Steel Tank with Locking Cap
Fuel Capacity (L)	100
Filtration	Filter with Water Separator and Indicator Sensor

ELECTRICAL (continued)

Voltage	12V Negative Earth
Alternator Capacity	12V-110 amp
Battery Specification	Heavy Duty 115D31L
Headlamp Type (W)	Halogen 2 x 55/60
Fog lamp in bumper	Standard

CLUTCH

Clutch Model	DUONIC Automated Manual (no clutch pedal)
Type	Dual Clutch (Wet Multi-plate)

TRANSMISSION

Version	FUSO DUONIC M038S6
Type / Speeds	6 Speed Automated Manual with Auto and Manual Modes
Features	Virtually Instant Gear Changes In-Dash Gear Lever with Park Brake Position ECO Mode to Minimise Fuel Usage
Ratios	1st: 5.397 5th: 1.000 2nd: 3.788 6th: 0.701 3rd: 2.310 Rev. 5.397 4th: 1.474
PTO Opening	LH Side

FRONT AXLE

Axle	FUSO F200T Independent Front Suspension Type
Design Capacity (kg)	2,300
Max Operating Capacity (kg)	2,300

FRONT SUSPENSION

Type	Double Wishbone Independent Front Suspension with Coil Springs and Shock Absorbers
------	--

REAR AXLE

Axle	FUSO D03 Full Floating Banjo Type
Ratio	4.444:1
Design Capacity (kg)	3,800
Max Operating Capacity (kg)	3,800

REAR SUSPENSION

Type	Steel Suspension
Details	Taper Leaf Spring with Stabiliser Bar and Double Acting Shock Absorbers
Size Main Leaves (mm)	1100 x 70

STEERING

Power Assisted	Tilt/Telescopic Adjustable Steering Wheel
----------------	---

BRAKES

Type	Hydraulic Dual Circuit with Front and Rear Single Calliper Discs
Size Front / Rear (mm)	276 x 28

SPECIFICATIONS - CANTER 516 CITY CREW CAB

BRAKES (continued)

Features	ABS plus EBD (Electronic Brake Distribution) Exhaust Brake Brake Priority System
Park Brake	Transmission Mounted

WHEELS AND TYRES

Wheel Type	7 x Single Piece Disc Rims (Including Spare)
Wheel Size	15.0 x 5.0K-115
Wheel Stud Pattern	5 Stud 208 PCD
Tyre Size All	195 / 85R15
Spare Tyre Carrier	Provided

CHASSIS

Type	Reinforced Tapered Channel
Size (mm)	188 x 60 x 4
Width (mm)	700

Refer to the bodybuilders guidelines on the Fuso website (www.fuso.co.nz) before mounting a body or modifying the chassis

INSTRUMENTS

Gauges	Speedometer with Odometer Tachometer; Fuel Level; Water Temperature
Colour Information Display	Fuel Consumption DPF Bar Chart from 1~9 Water Temperature Maintenance Reminder System Tripmeters

STANDARD FEATURES

Airbag(s)	Dual Air Bags and Seat Belt Pre-Tensioners (Driver and Far Side Front Passenger)
Hill Start System	Yes
Speed Limiter	Activated and adjustable by Fuso dealer
Cab Cooling and Heating	Air Conditioner / Heater / Demister
Accessory Power	12V Accessory Power Outlet / Cigar Lighter
Driving	AM/FM CD + USB + AUX + Bluetooth Hands Free Keyless Central Locking Electric Windows (front only) LED Map Lamp and Fluorescent Cabin Lamp Cup Holders (2)
Storage	Dual Overhead Storage Pockets In-Dash Centre Document Storage Door Storage Pockets Storage Under Rear Crew Seats Coat Hooks
Cab: External	Front Step Lights
Chassis	Reverse Warning Buzzer

KERB WEIGHTS AND MAX AXLE LOADS (kg)

Model		Vehicle Ratings**		Max Axle Loadings**		Kerb Weights*		
		GVM	GCM	Front	Rear	Front	Rear	Total
4x2 516 City Crew Cab 6 Sp. AMT	FEA21ER3WFAC	4,983	8,483	2,300	3,800	1,515	665	2,180

* Weights (est.) includes 10L fuel and spare wheel and are subject to 2.5% variation (+/-)

** Vehicle ratings and max axle loadings may be limited by local regulations.

CAB FEATURES

Type	All Steel Forward Control Fixed Cab
Cab Structure	Front Door Side Impact Beams
Mounting	6 Point Isolated Rubber
Additional Engine Access	Removable Engine Access Panel
Colour	Natural White (W31)
Windscreen Wipers	2 Speed + Intermittent Cycle with Integrated Washer Nozzles
Rear Vision Mirrors	1 x Internal 2 x External Convex Heated
Interior	Fully Trimmed cab with vinyl floor covering
Seating Capacity	6
Seat Belts	Driver - Height adjustable ELR 3 Point with tension reducer Outside Passengers - ELR 3 point Centre Passenger - Lap belt
Seat (driver)	Heavy Duty with LH Arm Rest , Adjustable Lumbar Support and Weight Adjustment. Cloth Trim
Seats (front passengers)	Flat Folding, 2 Passenger Bench with headrest in outside position
Seats (crew cab rear)	Low Back Bench Seat with headrests in outside position

SERVICE INTERVALS

Please contact your nearest Fuso dealer for details

WARRANTY

36 months or 100,000km (whichever occurs sooner)
Subject to terms and conditions in the Fuso Warranty Booklet

PERFORMANCE

Turning Circle (kerb to kerb - metres)	9.8
Road Speed (km/h) at Max Engine Speed	144
Engine Speed (rpm) at 90km/hr (top gear)	2150
Gradeability at Rated GVM (theoretical)*	41%
Notes	*This is theoretical performance only. Actual performance may vary under different conditions

SPECIFICATIONS - CANTER 516 CITY CREW CAB

DIMENSIONS (mm)

	E Wheelbase
Wheelbase	3,400
Length Overall	5,785
Height Overall	1,995
Width Overall	1,865
Width Rear Axle	1,865

	E Wheelbase
Width Front Track	1,390
Width Rear Track	1,435
Width Frame	700
Height Frame at Rear Axle	729

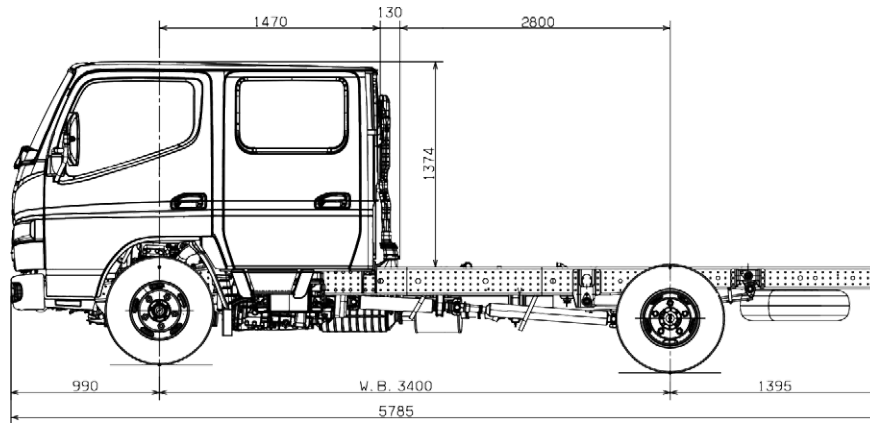

CANTER 516 CITY CREW CAB – ‘E’ WHEELBASE

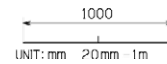

Scale = 1:50 (20mm = 1 metre). This scale is accurate when used on the original spec sheet, be aware that enlarging these illustrations can alter the scale and cause incorrect measurements. Fuso New Zealand and its authorised dealers always recommend customers seek professional advice from independent sources before commencing any engineering activities.

A policy of continual improvement means that specifications detailed in this brochure are subject to change without notice. Contact your authorised Fuso dealer to confirm current specifications. Fuso is a registered trademark of Mitsubishi Fuso Truck & Bus Corporation. Copyright © Fuso NZ (2017)